

MODEL: **572-035**



Travel made easy ✓

2 RIB SIDE WINDER BASE PLATE UNIT 50MM DIAMETER - DOUBLE CLAMP UNIT

- Ideal for crowded draw bars where space is limited.
- BOS® heavy duty double clamp is adjustable, allowing you to gain extra height if required.
- BOS® Patented Gearbox features a unique 12mm drive and provides effortless operation with a cordless drill or manual handle as a backup.
- LMATS Tested up to 1800kg in a rigid clamp setup.
- 350mm Extended travel.
- Unit can be left on while travelling, locking it in with medium clutch setting and the BOS® travelling strap.
- Will fit Draw Bars (chassis) from 75-150mm (4"-6") High x 50mm (2") Wide.
- The articulated base plate kit will adjust to uneven ground up to 30° and is great if you have no need for a wheel.
- 120mm Pipe extension when extra height is needed.
- Optional 8" double offset wheel can be attached.

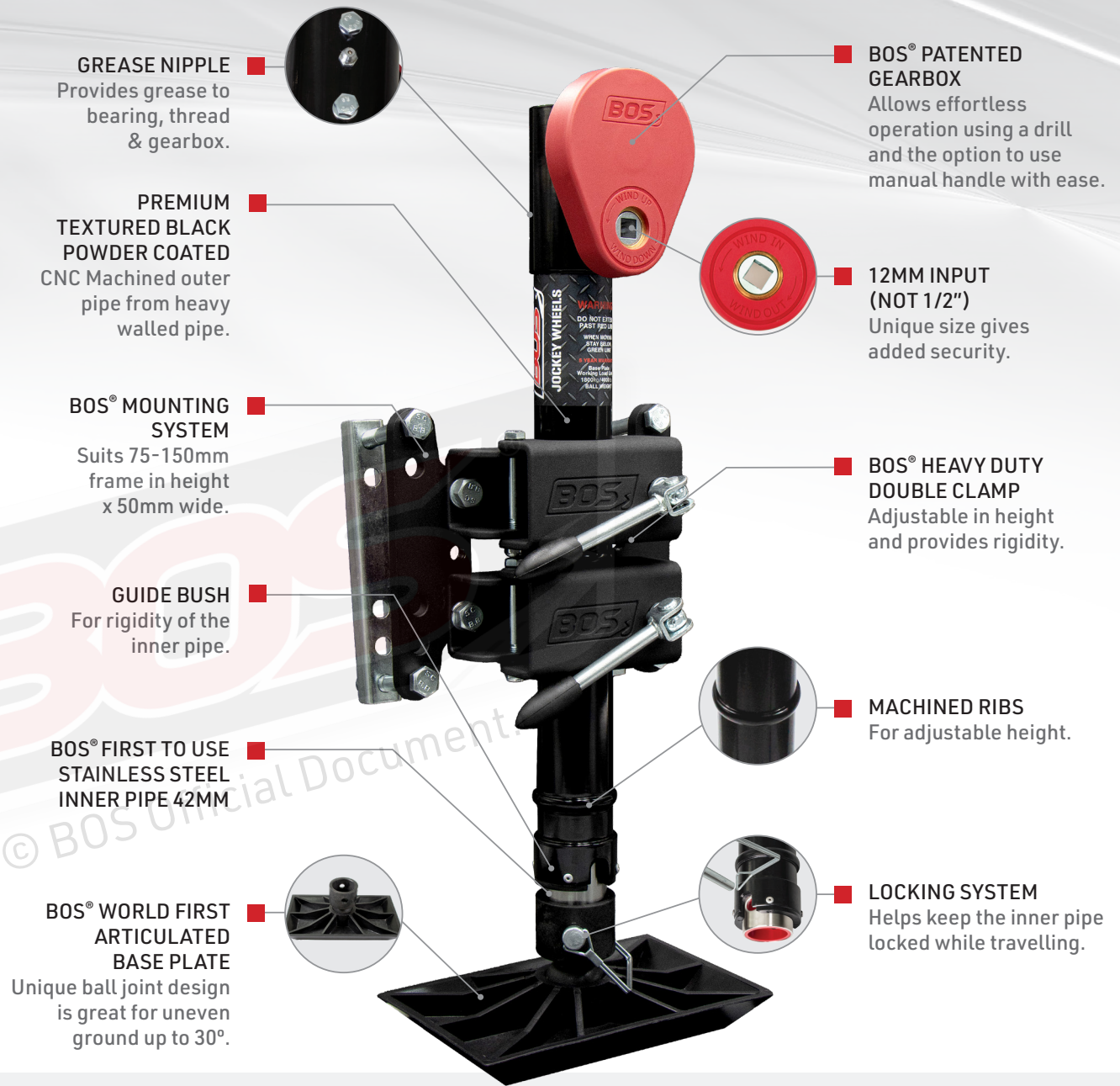

With you all the way!



BOS Jockey Wheels & Accessories Pty Ltd.

02 9623 6922 | sales@bos370.com.au | www.bos370.com.au

100 % Australian Family Owned & Operated

TRAVEL POSITION WITH-OUT BASE PLATE

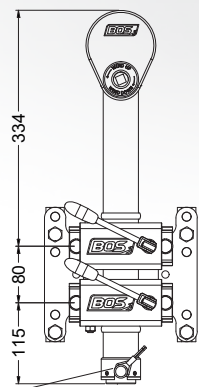

RETRACTED WITH BASE PLATE

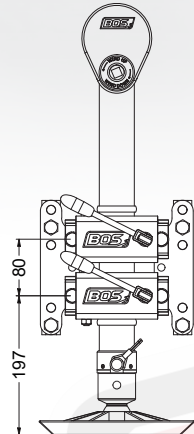

SIDE VIEW

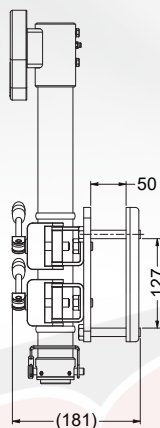

MAXIMUM EXTENSION WITH BASE PLATE

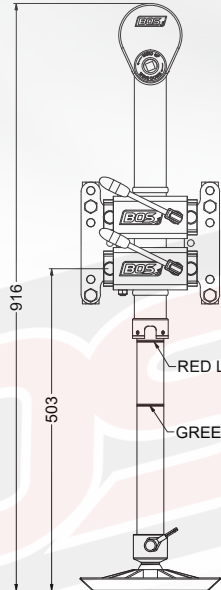

MAXIMUM EXTENSION WITH 120mm EXTENSION & BASE PLATE

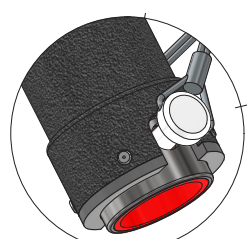
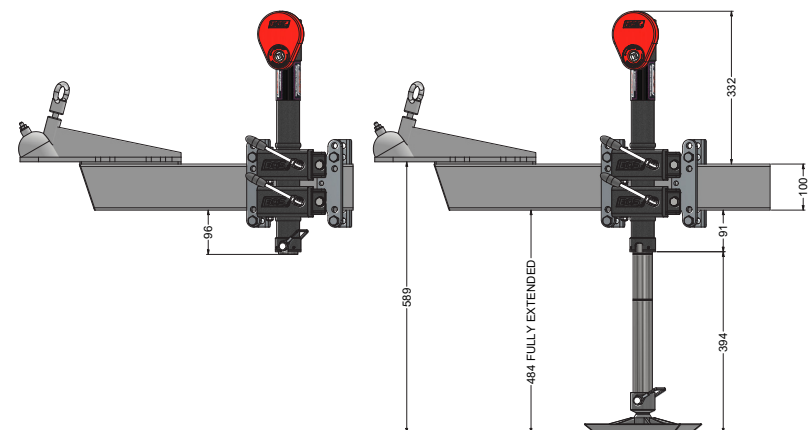
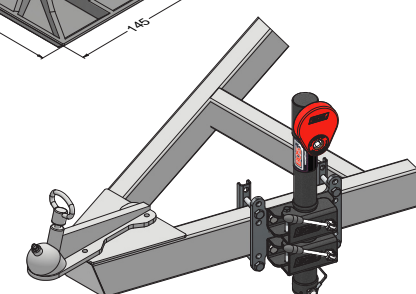
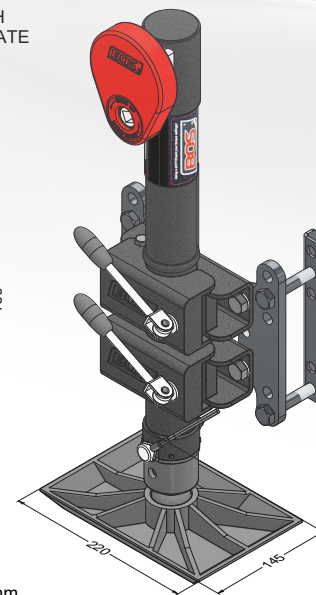
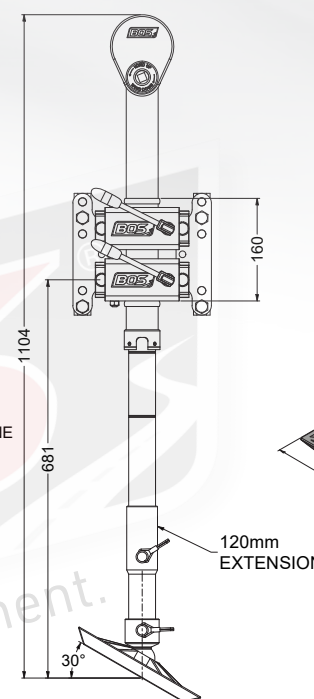

FULLY RETRACTED WITH LYNCH PIN TO LEAVE ON WHILE TRAVELLING

KIT INCLUDES

010-033

BOS® Mounting Kit will fit chassis (Draw Bar) from 75-150mm high x 50mm wide with U-Bracket and mounting bolts m12 x 85



010-062

Swivel Base Plate (HDFR) Nylon



020-018

x2 Quick Release Pins



020-026

Stainless Steel Extension 120mm



020-007

12mm Drill Drive Piece



010-036

BONUS BOS® Stubby Bottle Cooler



010-035

BONUS BOS® Stubby Can Cooler



020-037

BOS® Jockey Weather Cover



370-STRAP

BOS® Travel Strap



020-003

Handle 12mm (HDFR) Nylon

