

MODEL: **473-020**



Travel made easy ✓

3 RIB GEARBOX BASE PLATE UNIT 50MM DIAMETER - CENTRE MOUNT CLAMP

- Ideal replacement for electric centre type jacks.
- BOS® heavy duty centre mounted clamp is adjustable, allowing you to gain extra height if required.
- BOS® Patented Gearbox features a unique 12mm drive and provides effortless operation with a cordless drill or manual handle as a backup.
- Will fit onto the 3 hole centre mounting point.
- LMATS Tested up to 1800kg in a rigid clamp setup.
- 400mm Extended travel.
- Unit can be left on while travelling, locking it in with medium clutch setting and the BOS® travelling strap.
- The articulated base plate kit will adjust to uneven ground up to 30° and is great if you have no need for a wheel.
- 120mm Pipe extension when extra height is needed.
- Optional 8" double offset wheel can be attached.

BOS® PATENTED GEARBOX
Allows effortless operation using a drill and the option to use manual handle with ease.

MACHINED RIBS
For adjustable height.

BOS® HEAVY DUTY CENTRE MOUNT CLAMP
Adjustable in height and suits a 3 hole centre mounting point.

BOS® FIRST TO USE STAINLESS STEEL INNER PIPE 42MM

BOS® WORLD FIRST ARTICULATED BASE PLATE
Unique ball joint design is great for uneven ground up to 30°.

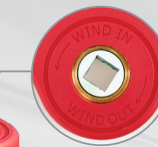

12MM INPUT (NOT 1/2")
Unique size gives added security.

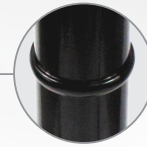

GREASE NIPPLE
Provides grease to bearing, thread & gearbox.

PREMIUM TEXTURED BLACK POWDER COATED CNC Machined outer pipe from heavy walled pipe.

GUIDE BUSH
For rigidity of the inner pipe.

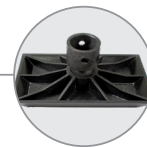

LOCKING SYSTEM
Helps keep the inner pipe locked while travelling.



With you all the way!



BOS Jockey Wheels & Accessories Pty Ltd.

02 9623 6922 | sales@bos370.com.au | www.bos370.com.au

100 % Australian Family Owned & Operated



Travel made easy

3 RIB GEARBOX BASE PLATE UNIT

50MM DIAMETER - CENTRE MOUNT CLAMP

MODEL: **473-020**

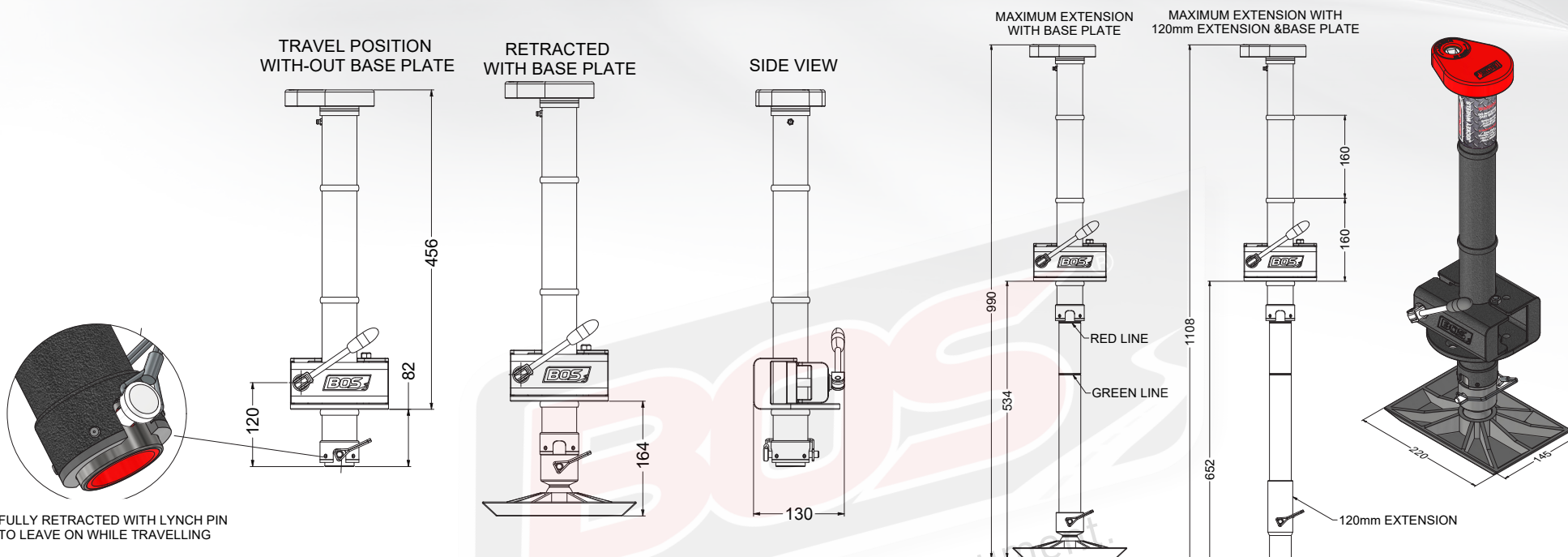

FULLY RETRACTED WITH LYNCH PIN TO LEAVE ON WHILE TRAVELLING

KIT INCLUDES

020-003

Handle 12mm (HDFR) Nylon



010-062

Swivel Base Plate (HDFR) Nylon



010-036

BONUS BOS® Stubby Bottle Cooler



010-083

BOS® Centre Mount Clamp USA



020-018

x2 Quick Release Pins



010-035

BONUS BOS® Stubby Can Cooler



020-026

Stainless Steel Extension 120mm



020-007

12mm Drill Drive Piece



370-STRAP

BOS Travel Strap



020-037

BOS Jockey Weather Cover

