

Starlink Integration Kit

User Manual and Installation Guide



cowfish

Caravan and Camping Technologies

cowfish.com.au

Starlink Integration Kit

PREFACE AND COPYRIGHT

Cowfish Technologies Pty Ltd reserves the right to revise this publication and to make changes in the content hereof without obligation to notify any person or organization of such revisions or changes.

Manual Revision V2.0

Cowfish Technologies and the Cowfish logo are trademarks or registered trademarks of Cowfish Technologies Pty Ltd in Australia. VanConnect and the VanConnect logo are trademarks or registered trademarks of Cowfish Technologies Pty Ltd in Australia. All other company or product names mentioned herein are trademarks or registered trademarks of their respective companies.

Copyright © 2023 Cowfish Technologies Pty Ltd.
All rights reserved. This publication may not be reproduced, in whole or in part, without prior expressed written permission from Cowfish Technologies Pty Ltd.



cowfish
technologies

Starlink Integration Kit

Table of Contents

PREFACE AND COPYRIGHT	2
PACKAGE CONTENTS	4
OPTIONAL ADDITIONAL CONTENTS	5
INTRODUCTION	8
HARDWARE OVERVIEW	9
INSTALLATION	11
OPTIONAL INSTALLATION - GEN 2 WEATHERPROOF	12
OPTIONAL INSTALLATION - GEN 2 ADAPTER	22
OPTIONAL INSTALLATION - GEN 3 WEATHERPROOF	24
OPERATION	28
TECHNICAL SPECIFICATIONS	30
TROUBLESHOOTING	33
PRODUCT WARRANTY	34



Starlink Integration Kit

PACKAGE CONTENTS

Starlink Integration Kit

The Starlink Integration Kit is a 12V to 57V converter, specifically designed to power the gen 1, gen 2 and gen 3 Starlink dish.



Starlink Integration Kit



Standard power cable or Anderson power cable



Starlink Integration Kit

OPTIONAL ADDITIONAL CONTENTS

Option A - Starlink Gen 2 Weatherproof external connection

This option includes a weatherproof connection point for on the outside of the caravan or motorhome. The connection point has an integrated cap and is rated IP65, meaning weatherproof and dust proof. The Starlink cable requires to be cut for this option and our weatherproof plug installed on the end of the cable.



Weatherproof socket



Weatherproof cap



Weatherproof plug

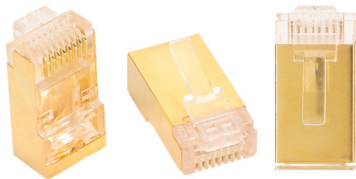

RJ45 connectors



Patch cable adapter



0.4 metre
ethernet cable



1 metre or 6 metre
ethernet cable



Starlink Integration Kit

Option B - Starlink Gen 2 adapter

This option includes a specially designed Starlink adapter that removes the requirement to cut the cable. Simply connect the standard Starlink cable into the SPX to RJ45 adapter.

The adapter is not weatherproof and therefore should be installed in a media hatch or tunnel boot.



SPX to RJ45 Adapter



0.4 metre
ethernet cable



1 metre or 6 metre
ethernet cable



Starlink Integration Kit

Option C - Starlink Gen 3 Weatherproof external connection

This option includes a weatherproof connection point for on the outside of the caravan or motorhome. The connection point has an integrated cap and is rated IP65, meaning weatherproof and dust proof.

The Starlink cable does not require to be cut for this option.



Weatherproof socket and cap



Weatherproof plug



0.8 metre
ethernet cable



1 metre or 6 metre
ethernet cable



INTRODUCTION

The Cowfish Starlink Integration Kit allows you to operate your Starlink Dish from your 12V battery system, ensuring reliable and consistent connectivity even in the most remote locations. The Starlink Integration Kit removes the requirement to run an inverter to power the Starlink System but instead powers the Dish directly from your caravan battery. By using the Integration Kit instead of the standard Starlink router, the power usage of the Starlink dish is significantly reduced, allowing you to stay off grid for longer.

The Integration Kit links the Starlink dish to the VanConnect system and allows you to choose the best internet option for your needs, 4G/5G or Starlink, or even have both. By having both 4G/5G and Starlink, you can pause the Starlink service whilst in a good 4G/5G coverage area.

The Integration Kit is not a standalone product, but instead an Add On for the VanConnect System. A VanConnect 5G, VanConnect 4G or VanConnect Zero is required in order to use the Integration Kit.

The VanConnect 5G, VanConnect 4G and VanConnect Zero are preconfigured to accept an internet connection from Starlink through our Integration Kit. There is no additional setup or configuration required.

NOTE: VanConnect system is sold separately. Starlink Dishy not included and an active Starlink subscription is required.



Starlink Integration Kit

HARDWARE OVERVIEW

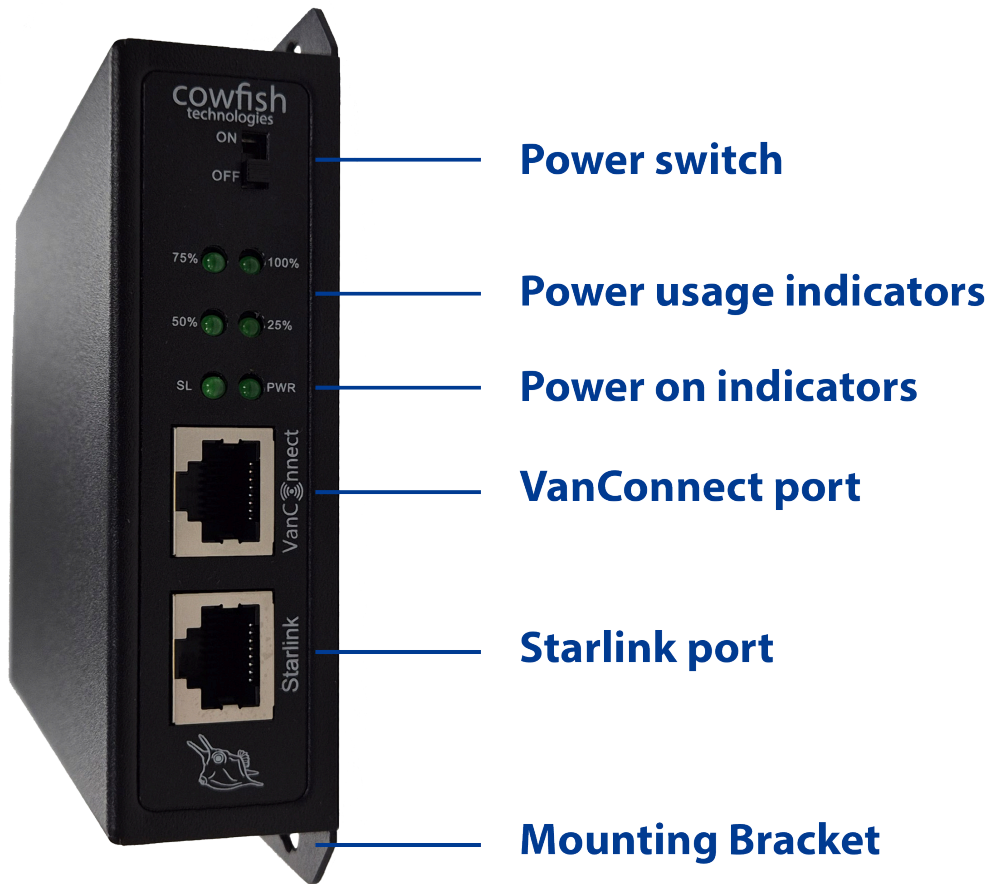

Starlink Integration Kit

Power connector

The Starlink Integration Kit receives 12V power through this XT60 power connector.

LED indicators

The unit has six LED indicators.

- The Power LED indicates if the unit is turned ON.
- The Starlink LED indicates that the unit is sending 57V to the Starlink Dish. This LED will blink as it is intermittently checking the status of the connection and will turn off if it diagnosis a fault.
- The four power usage LED's indicate the amount of power that the Starlink dish is using.
 - one LED up to 40W
 - two LED's up to 80W
 - three LED's up to 120W
 - four LED's up to 165W

Power switch

The ON/OFF switch turns the unit on and off and thus controls the 57V output for the Starlink Dish.

VanConnect port

The VanConnect is linked to the Integration Kit via this port.

Starlink Port

The Starlink Dish is connected to the Integration Kit via this port.

CAUTION: This port will have a live 57V power supply when the ON/OFF switch is placed in the ON position.

Mounting bracket

Mounting brackets are located on the top and bottom of the 12V Dishy Power Supply to mount the unit to a wall inside the caravan.



Starlink Integration Kit

INSTALLATION

Installation of the Starlink Integration Kit

The Integration Kit is to be installed next to the VanConnect system. Mount the unit next to the VanConnect and connect the Integration Kit to the VanConnect with the included 0.4 metre shielded ethernet cable.

On the Integration Kit, the ethernet cable is plugged into the port labelled "VanConnect". On the VanConnect, the ethernet cable is plugged into the port labelled "WAN".



In order to supply input power to the Integration Kit, a minimum of 12 AWG (4.0 mm²) electrical wire is required. This cable is to be correctly fused and installation by a certified auto electrician is advised. The Integration Kit comes with a pre terminated lead for easy wiring. Connect the 12V positive wire (red) to the terminal labelled + and the 12V negative wire (black) to the terminal labelled -.

IMPORTANT: Insufficient power supply to the Integration Kit, due to inadequate cable size, long cable runs, or piggy backing of existing power outlets instead of connecting to the power source (battery) can result in the



cowfish
technologies

Starlink Integration Kit

OPTIONAL INSTALLATION - GEN 2 WEATHERPROOF

Option A - Starlink Gen 2 Weatherproof external connection

Option A of the Starlink Integration Kit incorporates a weatherproof connection point for on the outside of your caravan.

A specialised connector is installed on the end of your Starlink cable, providing a full weatherproof connection on the outside of your caravan. The Starlink cable is required to be cut and the Weatherproof plug installed. An RJ45 crimp tool and a solder iron are required for the installation of the Weatherproof plug.

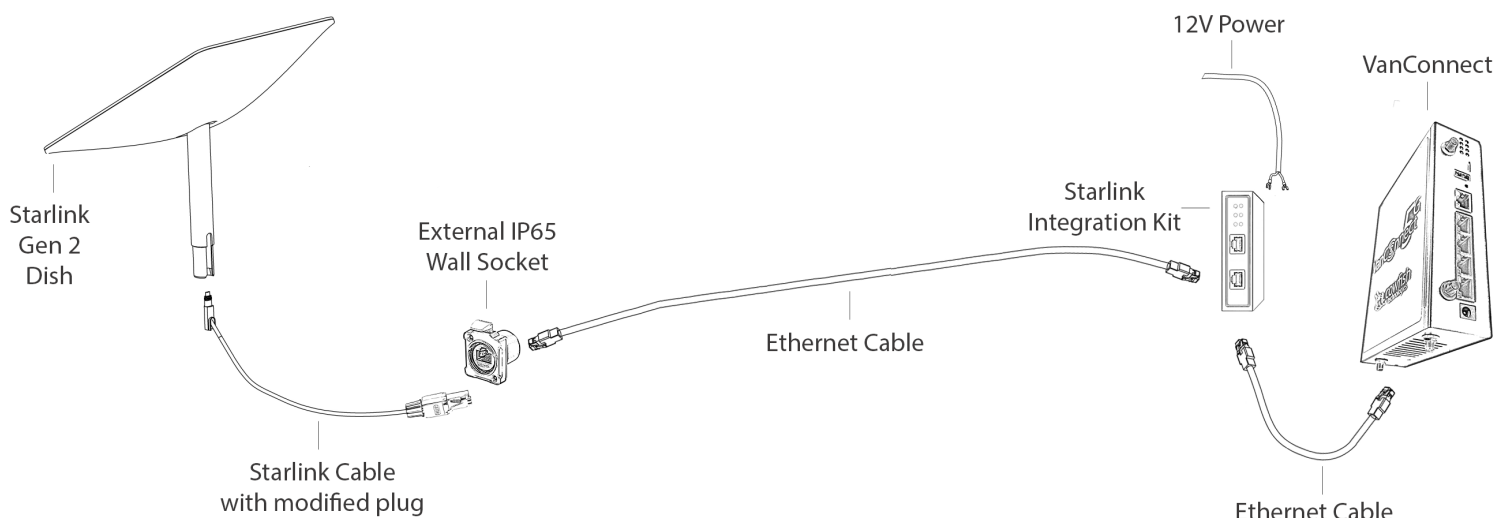

The kit consists of the following components:

- Starlink Integration Kit (12V dishy power supply)
- Weatherproof wall socket
- Weatherproof cap for wall socket
- Weatherproof male plug for gen 2 Starlink cable
- Patch cable connector
- 3x Shielded RJ45 plug
- 0.4 metre ethernet cable
- 1.0 metre or 6.0 metre ethernet cable (customers choice)



Starlink Integration Kit

Installation of the Weatherproof wall socket

Determine the location where the Weatherproof wall socket is to be installed. Ensure that there is a cable patch available from the 12V Dishy Power Supply to the nominated location for the Weatherproof wall socket and that the ethernet cable is of sufficient length.

1. Run the 1 metre or 6 metre shielded ethernet cable from the 12V Dishy Power Supply to the preferred location of the Weatherproof wall socket.
2. Drill a hole with a diameter of 24 mm into the external wall of the caravan.
3. Connect the Weatherproof wall socket to the 12V Dishy Power Supply with the 1 metre or 6 metre shielded ethernet cable. On the 12V Dishy Power Supply, the ethernet cable is plugged into the port labelled "Starlink".
4. Mount the Weatherproof wall socket to the caravan wall and ensure the seal is water tight by utilising the included rubber seal and by applying non-hardening silicone around the perimeter of the wall socket.
5. Connect the Weatherproof cap into the Weatherproof wall socket and secure the chain of the Weatherproof cap to the external wall of the caravan.



Starlink Integration Kit

Installation of the Weatherproof plug

In order to connect the new Weatherproof plug onto the Starlink cable complete the following steps:

1. Cut the cable at least 300mm from the Starlink plug, so that there is sufficient cable to make a patch lead.

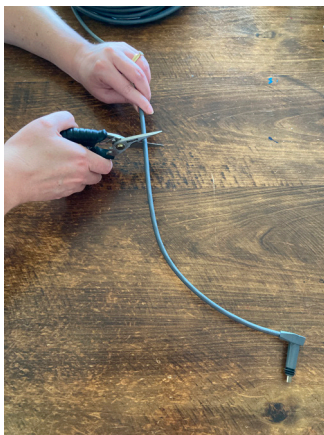

2. Unscrew the cap from the Weatherproof socket and remove the insert.
3. Slide the cap and the insert over the Starlink cable.



4. Strip the Starlink cable sheath back 25 mm from the end.



Starlink Integration Kit

5. Remove the light blue aluminium foil back to the cable sheath. Take care to not remove or cut the grounding wire.



6. Fold the grounding wire back and remove the clear foil back to the cable sheath.



7. Untwist and straighten the wires inside of the cable.

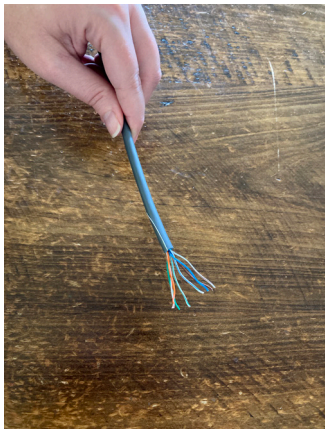

Starlink Integration Kit

8. Arrange the wires into the correct order. The proper sequence is as follows from left to right: Orange/White, Orange, Green/White, Blue, Blue/White, Green, Brown/White, Brown. This pin layout is named T568B.

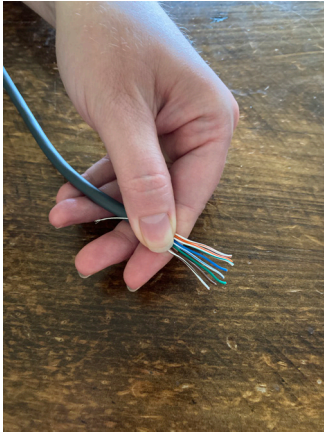

RJ45 Pinout T-568B

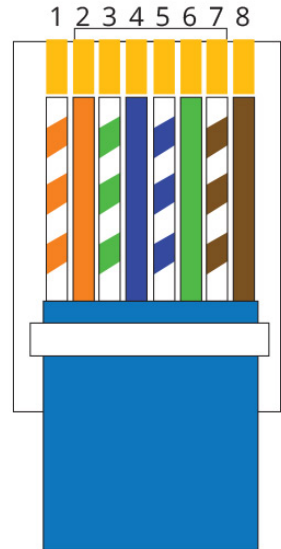
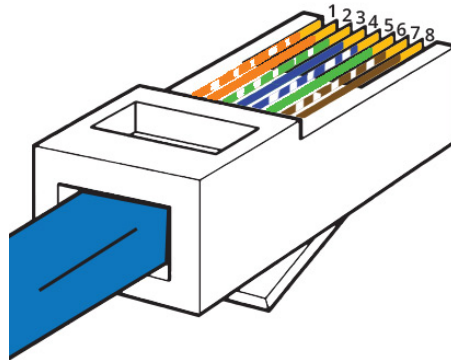

1. White Orange	5. White Blue
2. Orange	6. Green
3. White Green	7. White Brown
4. Blue	8. Brown

9. Cut the wires into an even line 13 mm from the sheathing. Hold the wires with your thumb and index finger to keep them in order. Then, use the cutting section of the crimping tool to cut them into an even line. The wires must be in an even line to be crimped into the RJ45 connector properly.

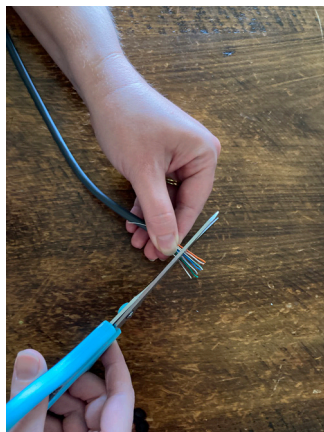

Starlink Integration Kit

10. Insert the wires into the RJ45 connector. Hold the RJ45 connector so the clip is on the underside and the small metal pins are facing up. Insert the cable into the connector so that each of the small wires fits into the small grooves in the connector. The sheathing of the cable should fit just inside of the connector so it's past the base. If any of the small wires bend or don't fit into a groove correctly, take the cable out and straighten the wires with your fingers before trying again. The wires must be inserted in the correct order and each wire must fit into a groove before you crimp the connector.



Starlink Integration Kit

11. Insert the connector into the crimping tool. Squeeze the handles to crimp the connector and secure the wires. The crimping tool pushes small pins in the grooves down onto the wires to hold and connect them to the RJ45 connector.



12. Remove the cable from the tool and check that all of the pins are down. If any of the pins aren't pushed down, put the wire back into the crimping tool and crimp it again.
13. Solder the grounding wire onto the metal shield of the RJ45 plug.



Starlink Integration Kit

14. Insert the cable with the newly attached RJ45 plug into the Weatherproof plug and push the plug until it clicks in place.



15. Push the insert into the Weatherproof plug and secure the cap back on the Weatherproof plug. The insert has a groove that is required to line up on the inside on the plug.



Your Weatherproof plug is now ready.



Starlink Integration Kit

Optional step; create a patch lead

To reconnect the Dish to the Starlink router after cutting the cable, a patch lead is required.

A patch lead is a length of cable with the original Starlink connector on one end and a RJ45 connector on the other end. With the Patch cable adapter we can attach the patch lead to the modified cable with the Weatherproof plug and reconnect to the Starlink router if required

In order to create the patch cable, complete the following steps:

1. Strip the Starlink cable sheath back 25 mm from the cut end.
2. Remove the light blue aluminium foil back to the cable sheath. Take care to not remove or cut the grounding wire.
3. Fold the grounding wire back and remove the clear foil back to the cable sheath.
4. Untwist and straighten the wires inside of the cable.
5. Arrange the wires into the correct order. The proper sequence is as follows from left to right: Orange/White, Orange, Green/White, Blue, Blue/White, Green, Brown/White, Brown.
6. Cut the wires into an even line 13 mm from the sheathing. Hold the wires with your thumb and index finger to keep them in order. Then, use the cutting section of the crimping tool to cut them into an even line. The wires must be in an even line to be crimped into the RJ45 connector properly.
7. Insert the wires into the RJ45 connector. Hold the RJ45 connector so the clip is on the underside and the small metal pins are facing up. Insert the cable into the connector so that each of the small wires fits into the small grooves in the connector. The sheathing of the cable should fit just inside of the connector so it's past the base. If any of the small wires bend or don't fit into a groove correctly, take the cable out and straighten the wires with your fingers before trying again. The wires must be inserted in the correct order and each wire must fit into a groove before you crimp the connector.
8. Insert the connector into the crimping tool. Squeeze the handles to crimp the connector and secure the wires. The crimping tool pushes small pins in the grooves down onto the wires to hold and connect them to the RJ45 connector.



Starlink Integration Kit

9. Remove the cable from the tool and check that all of the pins are down. If any of the pins aren't pushed down, put the wire back into the crimping tool and crimp it again. Solder the grounding wire onto the metal shield of the RJ45 plug.
10. Solder the grounding wire onto the metal shield of the RJ45 plug.
11. Use the Patch cable adapter to connect the two lengths of Starlink cable together.



Starlink Integration Kit

OPTIONAL INSTALLATION - GEN 2 ADAPTER

Option B - Starlink Gen 2 Adapter

Option B of the Starlink Integration Kit incorporates a Starlink Adapter. The Starlink Adapter converts the proprietary Starlink connector to a standard shielded RJ45 connection, allowing for the Dish to be connected to the Starlink Integration Kit. The adapter is not weatherproof and should therefore be used whilst running the Dish cable into the tunnel boot, media hatch or similar enclosure of your caravan.

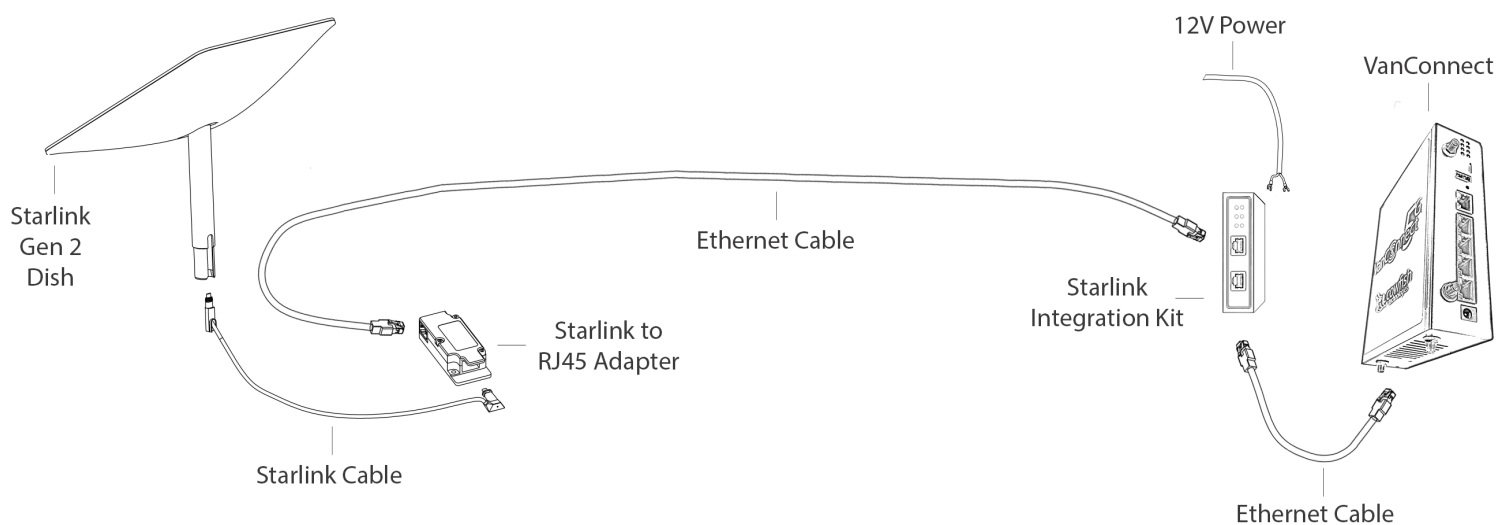

The kit consists of the following components:

- Starlink Integration Kit (12V dishy power supply)
- Starlink to RJ45 Adapter
- 0.4 metre ethernet cable
- 1.0 metre or 6.0 metre ethernet cable (customers choice)



Starlink Integration Kit

Installation of the Starlink Adapter

Determine the location where the Starlink Adapter is to be installed. Ensure that there is a cable patch available from the 12V Dishy Power Supply to the nominated location for the Starlink Adapter and that the ethernet cable is of sufficient length. The Starlink Adapter is not weatherproof and should therefore be installed in a location where it is protected from rain or any other ingress of water and dust.

1. Run the 1 metre or 6 metre shielded ethernet cable from the 12V Dishy Power Supply to the preferred location of the Starlink Adapter.
2. Connect the Starlink Adapter to the 12V Dishy Power Supply with the 1 metre or 6 metre shielded ethernet cable. On the 12V Dishy Power Supply, the ethernet cable is plugged into the port labelled "Starlink".
3. Mount the Starlink Adapter to the wall through the two mounting holes.



Starlink Integration Kit

OPTIONAL INSTALLATION - GEN 3 WEATHERPROOF

Option C - Starlink Gen 3 Weatherproof external connection

Option C of the Starlink Integration Kit incorporates a weatherproof connection point for on the outside of your caravan.

A specialised connector is installed on the end of your Starlink cable, providing a full weatherproof connection on the outside of your caravan. The Starlink plug is inserted into the Weatherproof plug without the need to modify the Starlink cable.

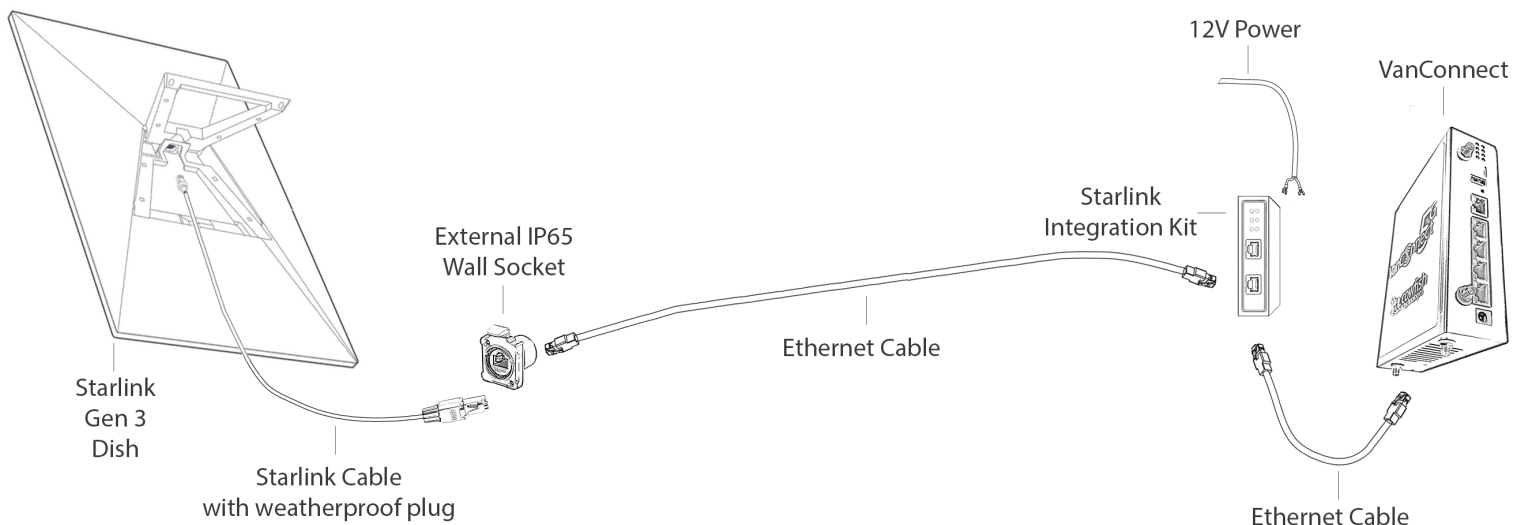

The kit consists of the following components:

- Starlink Integration Kit (12V dishy power supply)
- Weatherproof wall socket
- Weatherproof cap for wall socket
- Weatherproof male plug for gen 3 Starlink cable
- 0.8 metre ethernet cable
- 1.0 metre or 6.0 metre ethernet cable (customers choice)



cowfish
technologies

Starlink Integration Kit

Installation of the Weatherproof wall socket

Determine the location where the Weatherproof wall socket is to be installed. Ensure that there is a cable patch available from the Starlink Integration Kit to the nominated location for the Weatherproof wall socket and that the ethernet cable is of sufficient length.

1. Run the 1 metre or 6 metre shielded ethernet cable from the Starlink Integration Kit to the preferred location of the Weatherproof wall socket.
2. Drill a hole with a diameter of 24 mm into the external wall of the caravan.
3. Connect the Weatherproof wall socket to the Integration Kit with the 1 metre or 6 metre shielded ethernet cable. On the Integration Kit, the ethernet cable is plugged into the port labelled "Starlink".
4. Mount the Weatherproof wall socket to the caravan wall and ensure the seal is water tight by utilising the included rubber seal and by applying non-hardening silicone around the perimeter of the wall socket.
5. Connect the Weatherproof cap into the Weatherproof wall socket and secure the chain of the Weatherproof cap to the external wall of the caravan.



Starlink Integration Kit

Installing the weatherproof plug

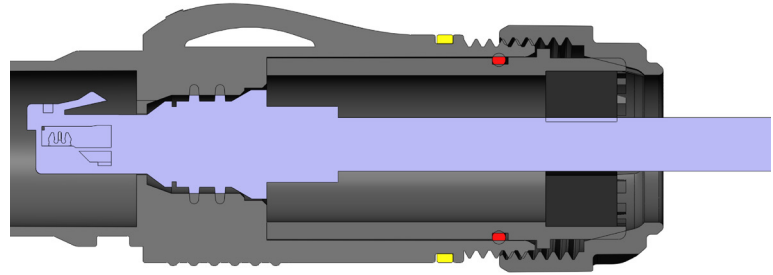

Step 1:
Pull the plug apart to separate all of the components.

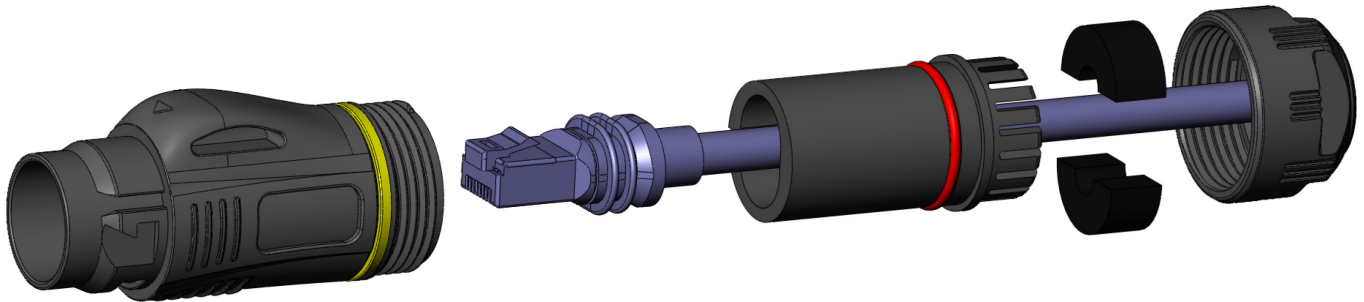

Step 2:
Feed the starlink cable through the screw cap and the internal housing.

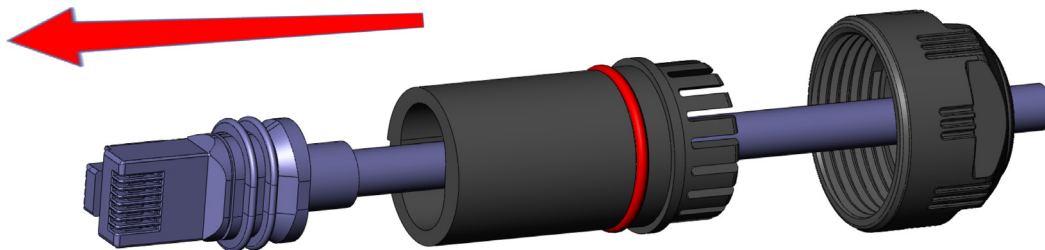

Step 2:
Rotate the starlink cable 90 degrees.

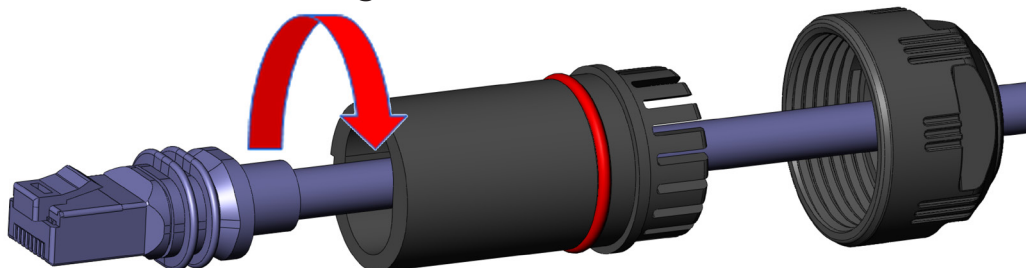

Starlink Integration Kit

Step 3:

Feed the Starlink cable into the external housing and push the plug until it clicks in place.

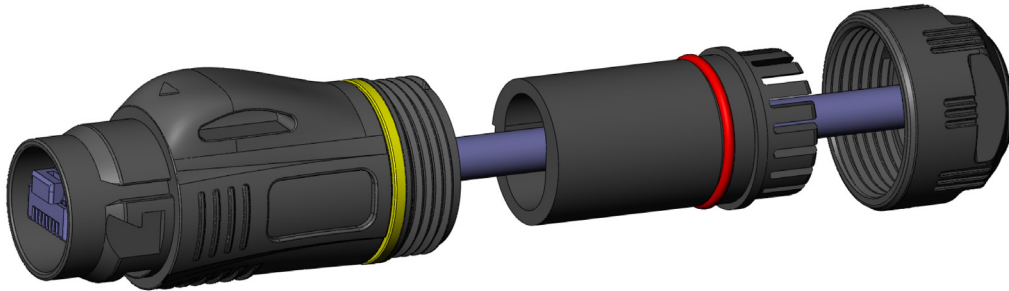

Step 4:

Insert the internal housing into the external housing. Ensure that the slot on the internal housing aligns with the pin in the external housing.

Step 5:

Place the two rubber half moons around the cable and gently push them into the back of the housing.

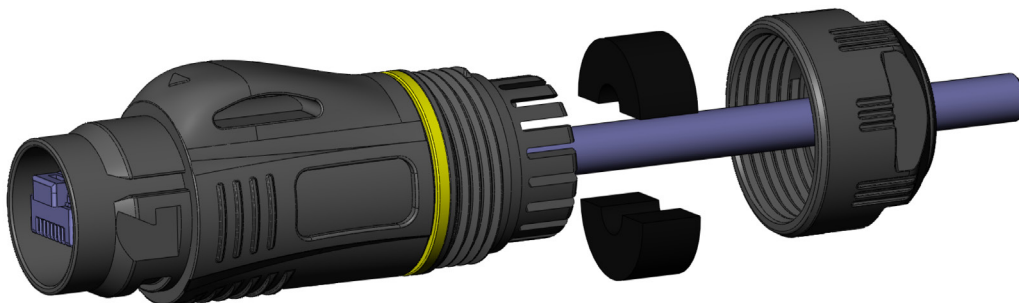

Step 6:

Screw on the cap to complete the installation.



Starlink Integration Kit

OPERATION

The VanConnect is pre-configured to accept a Starlink connection through the Starlink Integration Kit. There is no additional setup required when installing the Integration Kit.

The VanConnect 5G, VanConnect 4G and VanConnect Zero standard setup configurations are listed in the respective manuals. Please complete the standard VanConnect setup prior to enabling the Starlink Integration Kit.

To use the Starlink Integration Kit, follow the following steps:

1. Find an area to place the Starlink dish with a clear view of the sky.
2. Plug the Starlink cable into the weatherproof port for option A, or the Starlink adapter for option B.
3. Turn on the Starlink Integration Kit by placing the On/Off switch in the ON position.
4. After a few minutes, Starlink will make an initial connection to the Starlink constellation.

CAUTION: Do not connect the cable between the Starlink Integration Kit and the Starlink Dish whilst the Integration Kit is powered on. The Integration Kit will have a live 57V power supply when the ON/OFF switch is placed in the ON position and connecting the cable whilst the unit is on can permanently damaged the Integration Kit and Starlink Dish.

The easiest way to access the Starlink administration dashboard is through the Starlink app. The Starlink app is available for iOS and Android devices. If you haven't already, visit your app store and search for "Starlink".

To access the Starlink settings from the app, be sure you are connected to your VanConnect WiFi network. Also be sure you are logged in to your Starlink account in the app.

On the main screen of the app, you will find the status of your Starlink connection. You've successfully installed Starlink if your status is listed as Online.



Starlink Integration Kit

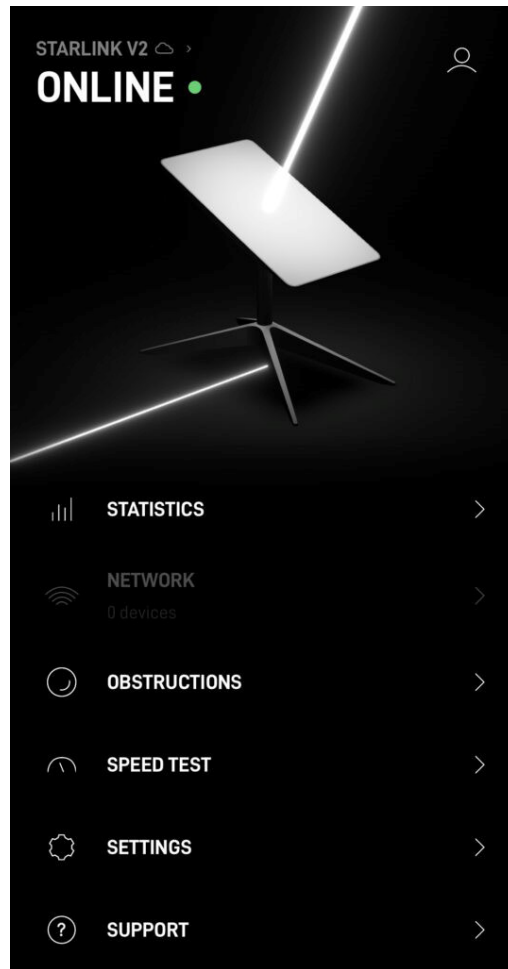

To turn off the Starlink dish simply turn off the 12V Dishy Power Supply by placing the On/Off switch in the OFF position. You can now safely disconnect the Dishy cable.

CAUTION: The cabling between the Starlink Integration Kit and the Starlink Dish must not be disconnected or unplugged whilst the Starlink Integration Kit is powered on (the On/Off switch in the ON position). Disconnecting the cable between the Integration Kit and the Starlink Dish whilst the unit is powered can result in permanent damage to the Starlink Integration Kit and the Starlink Dish.



Starlink Integration Kit

TECHNICAL SPECIFICATIONS

Data Speed	10/100/1000Mbps
Input power	DC12V / DC24V at max 14A
Output power	DC57V at max 3A
Max power rating	165W
Dimensions	135mm x 120mm x 30mm
Operating Temperature	-10 to 45°C
Storage Temperature	-20 to 70°C
Surge Protection	4KV
Electrostatic Discharge Protection	6KV
Regulatory Compliance	RoHS, CE, FCC



Starlink Integration Kit

FREQUENTLY ASKED QUESTIONS

Do I need to run an inverter to power the Starlink Integration Kit?

No, you will not need to run an inverter or have access to mains power (240V). The Starlink Integration Kit operates off your caravan 12V system, so that you can use it off grid, anywhere, anytime.

How much power does the Integration Kit use in comparison to the original Starlink hardware?

Normal Starlink power consumption when using the original Starlink router averages at 50-75W for the gen 2 system and 75-100W for the gen 3 system. On top of this you also have Inverter losses that range between 8-10% of the load for a high quality inverter. This means that the total Starlink power consumption for caravan use is between 55-80W for gen 2 and 80-110W for gen 3.

The Cowfish Integration Kit reduces this total power consumption to an average of 40W for gen 2 and 55W for gen 3, almost halving your power usage.

Do I need to modify the Starlink hardware?

For Option A you will need to cut the Starlink cable and install the weatherproof plug on the end of the cable.

For Option B you do not require to modify the Starlink hardware.

For Option C you do not require to modify the Starlink hardware.

Can I still use the Starlink App when using the Integration Kit?

Yes, the easiest way to access the Starlink router administration dashboard is through the Starlink app and this doesn't change when using the Integration Kit. The Starlink app is available for iOS and Android devices. To access Starlink from the app, be sure you are connected to your VanConnect Wifi network.



Starlink Integration Kit

How do I connect to the WiFi and Internet through the Starlink Integration Kit?

The Starlink Integration Kit is an Add On system to the VanConnect 5G, VanConnect 4G or VanConnect Zero. In order to connect to the Internet, you are required to have one of these VanConnect units. Please refer to the VanConnect manual for your model, for further details on how to set up the WiFi network.

Do I need to make any changes to the VanConnect in order to use the Starlink Integration Kit?

No, the VanConnect is preconfigured to accept the Integration Kit. The unit will automatically use Starlink internet when the integration kit is turned on, and switch back to 4G/5G when the Integration Kit is turned off.

Can I use the Starlink Integration Kit without the VanConnect system?

No, the Starlink Integration Kit is an Add On system to the VanConnect 5G, VanConnect 4G or VanConnect Zero. The Integration Kit supplies power to the Starlink Dish and integrates it with the VanConnect. It is not a standalone product.

Can I use the Integration Kit with a different router?

No, we cannot guarantee that the Integration Kit will operate as intended with a 3rd party router. The VanConnect is preconfigured to function with the Integration Kit.

What warranty is supplied with the product?

The Starlink Integration Kit comes with a 12 month warranty.



Starlink Integration Kit

TROUBLESHOOTING

The Power LED does not light up.

If the Power LED does not light up it means that there is no power coming to the Starlink Integration Kit. Please check the power cables and ensure that they are connected properly. Check if the power cables are fused, and if the fuse is still in working condition.

The Starlink LED does not light up.

If the Starlink LED does not light up it could mean that there is an ethernet cable connection fault. Turn off the power supply and disconnect the cable from the Starlink port. Turn the power supply back on, if the Starlink LED turns on it is a bad ethernet connection.

Check that all the cables are connected and seated properly. If the Starlink cable was cut and a RJ45 plug crimped on, verify the integrity of this plug. If required, remove the RJ45 plug and crimp on a new plug.

The Starlink Dish is not powering on.

Confirm that the Power LED and Starlink LED are both on. If both LEDs are on, but the Dishy is not powering up there is potentially a power supply fault, due to insufficient power supply to the 12v Dishy unit.

Ensure that the electrical cable size is adequate for the cable length and that the power is supplied directly from the 12V battery system, not from an existing power point in the caravan. Cigarette socket power points can have long cable runs, smaller electrical cabling, or wired in series, resulting in a power drop.

Dishy has powered up, but I don't have an internet connection.

Ensure that the cable between the Starlink Integration Kit and the VanConnect unit is connected properly. Confirm that the WAN LED on the VanConnect is lit up.

Open the Starlink app and confirm that the Dish has established an internet connection.

Review the VanConnect manual for further trouble shooting.

If you are not using a VanConnect, but a different router, please review the manufacturer's manual to ensure that the router is compatible and for information on how to set up the router to accept a Starlink connection.



Starlink Integration Kit

PRODUCT WARRANTY

At Cowfish Technologies Pty Ltd (Cowfish) we want our customers to be completely satisfied with their purchase. Our goods come with guarantees that cannot be excluded under the Australian Consumer Law. You are entitled to a replacement or refund for a major failure and for compensation for any other reasonably foreseeable loss or damage. You are also entitled to have the goods repaired or replaced if the goods fail to be of acceptable quality and the failure does not amount to a major failure.

Warranty Conditions

Cowfish offers the following warranty in relation to its goods.

The benefits of this warranty are in addition to any rights and remedies imposed by Australian State and Federal legislation that cannot be excluded. Nothing in this warranty is to be interpreted as excluding, restricting or modifying any State or Federal legislation applicable to the supply of goods and services which cannot be excluded, restricted or modified.

Cowfish warrants to the original purchaser that, subject to the exclusions and limitations below, all parts of the manufacture and assembly of the goods carried out by Cowfish will be free from defects in materials and workmanship for a period of 12 months from the date of purchase (Warranty Period).

This warranty is not transferable to a subsequent customer if the goods are sold by the original customer during the Warranty Period.

If a defect appears in Cowfish's manufacture or assembly of the goods before the end of the Warranty Period and Cowfish finds the goods to be defective in materials or workmanship, Cowfish will, in its sole discretion, either repair or replace the goods or the defective part of the goods free of charge, or provide a credit or exchange.

Cowfish reserves the right to replace defective parts of the goods with parts and components of similar quality, grade and composition where an identical part or component is not available. Goods presented for repair may be replaced by refurbished goods of the same type rather than being repaired. Refurbished parts may be used to repair the goods.

Where your rights under the Australian Consumer Law or this warranty do not apply, we may provide you with an indicative cost estimate to repair the goods.



cowfish
technologies

Starlink Integration Kit

Damaged goods

If any goods arrive damaged, please contact Cowfish as soon as possible so a Return Authority Number can be arranged for the goods to be inspected. Goods must be returned within a reasonable time. The acceptance of the goods delivered shall be deemed for all purposes to have taken place 30 days* from the date of delivery.

If a purchaser receives a product that is damaged in transit from Cowfish, the purchaser should: Refuse to accept delivery of the product; Direct the courier to "Return goods to sender"; and Notify the Cowfish Customer Service or Warranty Department immediately.

No goods will be accepted for return until a Return of Goods Authority Number has been supplied to you. Goods must be returned in the condition received by you with all original packaging, accessories and/ or manuals.

Returns and repairs

Goods returned for repair or credit will be assessed and repaired or replaced within a reasonable time. Credits will normally be processed within 14 days* of your goods being returned to Cowfish's nominated warehouse. Where goods have been assessed to be repairable under the manufacturers' warranty, you may be supplied with details of an authorised repairer. You may also be provided with an indicative repair and/ or replacement time, which may vary due to reasons beyond our control, or the repairer's reasonable control, such as part availability and incorrect fault description. Cowfish does not take any responsibility for any repairs and/ or replacements carried out without our prior written consent.

Where goods are assessed to have been damaged by misuse or accident, no credit will be issued and no further action will be entered into. Where your rights under the Australian Consumer Law or any manufacturer's warranty do not apply, we may provide you with an indicative cost estimate to repair the goods.

If a replacement item is required, Cowfish will require the location of the caravan and owners for the next 14 days to allow for pick, pack and postage. If the owners are traveling, Cowfish require next major town or city location. Otherwise, the warranty procedure as in place at present will remain.



Starlink Integration Kit

Replacement item warranty

Should a replacement item be supplied by Cowfish 'under warranty' due to damage or product failure of original item purchased, Cowfish will warrant the replacement item for the remaining warranty period only of the original item warranty.

Warranty Claims

If a fault covered by warranty occurs, the customer must first contact the Cowfish Customer Service or Warranty Department.

Any warranty claim must be accompanied by proof of purchase, full details of the alleged defect (including clear photos), and appropriate documentation (such as historical and maintenance records).

The customer must make the goods available to Cowfish or its authorised repair agent for inspection and testing.

If such inspection and testing finds no defect in the goods, the customer must pay Cowfish's usual costs of service work and testing. The customer must bear the cost of the transport of the goods to and from Cowfish or the authorised repair agent, and all insurance of the goods.

Goods returned for repair or credit will be assessed and repaired or replaced within a reasonable time.

Credits will normally be processed within 14 days* of your goods being returned to Cowfish's nominated warehouse. Where goods have been assessed to be repairable under this warranty, you may be supplied with details of an authorised repairer. You may also be provided with an indicative repair and/ or replacement time, which may vary due to reasons beyond our control, or the repairer's reasonable control, such as part availability and incorrect fault description. Cowfish does not take any responsibility for any repairs and/ or replacements carried out without our prior written consent.

If a replacement item is required, Cowfish will require the location of the caravan and owners for the next 14 days to allow for pick, pack and postage. If the owners are traveling, Cowfish require next major town or city location.

Limitations

Cowfish makes no express warranties or representations other than set out in this warranty.

The repair or replacement of the goods or part of the goods is the absolute limit of Cowfish's liability under this express warranty.



This page has intentionally been left blank



cowfish
technologies