



# ANTI-FLAP KIT PRO<sup>+</sup>

## Instructions Set 12



**READ CAREFULLY BEFORE USING  
RETAIN MANUAL FOR FUTURE REFERENCE**

Australian Design Application Nos. 202413656 & 202413657



Read this installation instruction thoroughly.  
 Incorrect installation or operation may void any warranty.  
 Incorrect use or operation may cause serious injury.

## PRODUCT INTRODUCTION

From the inventors and innovators of the original & the best Anti-Flap Kit, Aussie Traveller now brings you the Anti-Flap Kit Pro+ (AFKPRO+).

The AFKPRO+ includes favourable user improvements including lightweight design, (20% lighter than AFK LONG) and different attachments to suit most RV awnings on the market.

The AFKPRO+ will protect and keep your awning in perfect condition by securing the fabric to prevent wind flap. It is easy to install and now comes in one size to suit projections from 2100mm to 2500mm. The AFKPRO+ covers both sides of your awning and is broken down into 6 total pieces (3 per side) to make storing and transport that much easier!

Featuring the smart triple sail track design, the AFKPRO+ allows you to easily install walls, annexes, porches or fly awnings, giving you more time to enjoy your adventures. This well-designed and engineered product is available in your choice of black or white to complement your awning perfectly.

The Aussie Traveller Anti-Flap Kit has stood the test of time, with Aussie Traveller recognised as the creators of the original and the best Anti-Flap Kit. Trust us to continue to improve and enhance your experience when RV'ing with the new AFKPRO+.

## SPECIFICATIONS

### INCLUDES:

- A. Outrigger Bracket - Pair
- B. Spigot Ends for Cassette Awnings - Pair
- C. Spigot Ends for Cassette Awnings - Pair
- D. Annexe Support Bracket - Pair
- E. Paddle End - Pair
- F. 100mm Extension Piece - Pair
- G. Standard Hook - Pair (*pre-installed*)\*
- H. Standard Spigot - Pair (*pre-installed*)\*



**ANTI-FLAP KIT PRO+ – BLACK**  
 PART NUMBER: 24000000000080

**ANTI-FLAP KIT PRO+ – WHITE**  
 PART NUMBER: 24000000000020

<b>PRODUCT DIMENSIONS (LxWxH)</b>	2100 – 2500 × 60 × 75mm
<b>NET WEIGHT</b>	6kg
<b>PACKAGED DIMENSIONS (LxWxH)</b>	730 × 385 × 100mm
<b>GROSS WEIGHT</b>	6.4kg
<b>AUSTRALIAN REGISTERED DESIGN NO.</b>	202413656   202413657

# SET UP OF THE ANTI-FLAP KIT PRO<sup>+</sup>

**Step 1:** Unpack the AFKPRO<sup>+</sup> from carton. Select the two sections with hook ends (PART G). These sections have the joiner pieces fitted inside for transport and packing purposes. Remove the two set screws, slide the joiner piece out, reverse the direction and re-fix in place using the original set screws. **Fig.1**



**Fig. 1:**  
AFKPRO+  
Slide  
Sections

**Step 2:** Release the locking cam handles and ensure the top clamp section of the AFKPRO<sup>+</sup> is in the open position. Slide the center & hook end (PART G) sections of the AFKPRO<sup>+</sup> together plus 300mm extension pieces (Aussie Traveller part number is 02400005000001 white or 024000050000081 black which need to be purchased separately and are not included in AFKPRO<sup>+</sup>). Slightly tighten the locking knob so the pieces don't slide apart. **Fig.2**

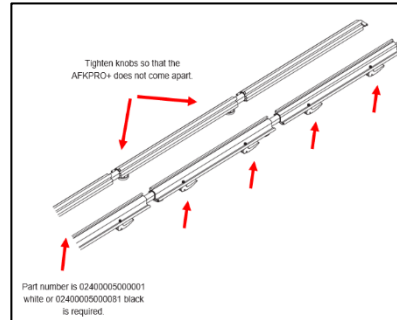

**Fig. 2:**  
Knobs and  
handles

**Step 3:** Remove the hook ends (PART G) by unscrewing the screw and pulling the hook end out of the AFKPRO<sup>+</sup> (Pliers may be needed). **Fig. 3**



**Fig. 3:**  
Remove Part  
G

**Step 4:** Select (PART F) and slide this into the end where the hook end (PART G) was removed from. Tighten this in place with the screw removed from the hook end. Repeat this for both ends where the hook end was removed **Fig. 4**



**Fig. 4:**  
Insert Part F

**Step 5:** Select (PART E) and slide this into the open end of (PART F) ensuring that the sliding part of (PART E) can slide to the underside of the of the awning. Tighten this in place with the screws provided. **Fig. 5**



**Fig. 5:**  
Insert Part E  
into Part F

**Step 6:** Select (PART B) and slide this into the open end of the 300mm extensions. Tighten this in place with the screw removed from the spigot end. Tighten this in place with the screws provided. **Fig. 6**



**Fig. 6:**  
Insert Part B  
into 300mm  
extensions.

# INSTALL THE ANTI-FLAP KIT PRO<sup>+</sup>

Aussie Traveller recommends Anti-Flap Kit Pro<sup>+</sup> (AFKPRO<sup>+</sup>) installation is performed by an Aussie Traveller Approved Service Partner.

## OPENING THE AWNING

1. Wind out the awning as per operating instructions for your model of awning.
2. The awning should be supported using drop down legs if applicable or by using tie down ropes (follow operating instructions for your model of awning) **Fig. 7 for reference.**



**Fig. 7:**  
Awning in open position.

## FITMENT OF AFKPRO<sup>+</sup>

1. Lay the AFKPRO<sup>+</sup> on either side of the opened awning, in position ready for install.
2. Slide the paddle fitting (PART E) over the shock absorber **Fig. 8 for reference**
3. Loosen the knobs on the center piece of the AFKPRO<sup>+</sup> and extend it to fit the width of the awning **Fig. 9 for reference**
4. Open the 5 handles to allow the awning vinyl to be clamped inside the AFKPRO<sup>+</sup> **Fig. 9 for reference**
5. Fit the AFKPRO<sup>+</sup> to the awning by pushing the black bracket (PART B) on the AFKPRO<sup>+</sup> onto the triangular bracket on the awning **Fig. 10 for reference**
6. Pull the two ends of the AFK PRO<sup>+</sup> apart to ensure it fits snugly between the van and the awning. Tighten the two knobs and then clamp the awning material inside the AFKPRO<sup>+</sup> and close the clamps as per **Fig. 11 for reference**

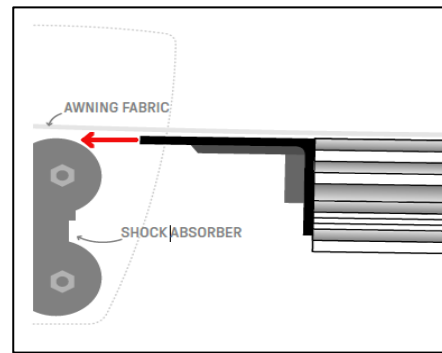

**Fig. 8:**  
Paddle end on shock absorber.

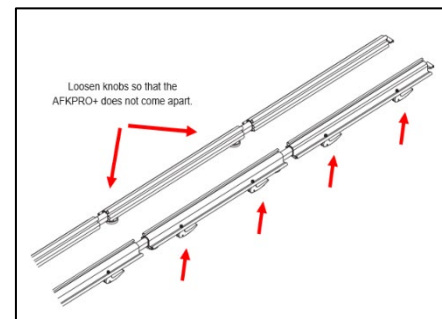

**Fig. 9:**  
Loosen Knobs and Open Handles.

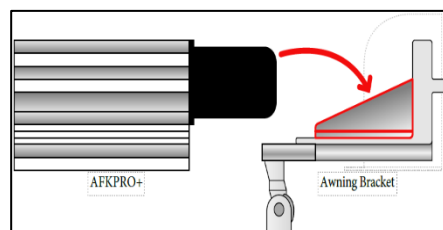

**Fig. 10:**  
PART B onto triangular bracket.

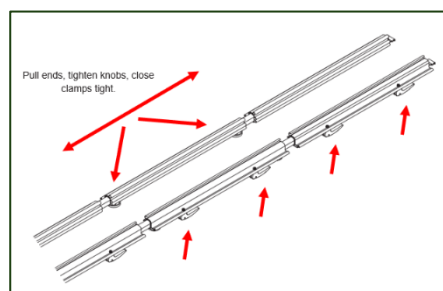

**Fig. 11:**  
Tighten knobs and close clamps.

# WARRANTY STATEMENT

Aussie Traveller Pty Ltd ACN 642 775 460 (**Aussie Traveller**) offers the following warranty in relation to the products it supplies directly or through an authorised manufacturer, dealer or approved service repair agent (**Product**).

## Australian Consumer Law

The benefits of this warranty are in addition to any rights and remedies imposed by Australian State and Federal legislation that cannot be excluded. Nothing in this warranty is to be interpreted as excluding, restricting or modifying any State or Federal legislation applicable to the supply of goods and services which cannot be excluded, restricted or modified.

If you are a consumer as defined in the Australian Consumer Law: *Our goods come with guarantees that cannot be excluded under the Australian Consumer Law. You are entitled to a replacement or refund for a major failure and compensation for any other reasonably foreseeable loss or damage. You are also entitled to have the goods repaired or replaced if the goods fail to be of acceptable quality and the failure does not amount to a major failure.*

## Warranty

Aussie Traveller warrants that, subject to the exclusions and limitations below, all parts of the manufacture and assembly of the Product will be free from defects in materials and workmanship (**Warranty**) for a period of 12 months from the date of purchase as follows:

1. This Warranty is activated at the time of purchase by the final retail customer (being the owner of the Product).
2. In the event the Product is purchased by a manufacturer, dealer or approved service repair agent, this Warranty will commence at the time the final retail customer makes payment for the Product to the wholesale purchaser.
3. If the Product is purchased directly from Aussie Traveller for use by final retail customer and not to be on sold in any way, the Warranty will commence at the time of the original purchase.

## Warranty Period

This Warranty cannot be assigned or transferred to a subsequent owner of the Product.

The purchaser or final retail customer should inspect the Product immediately when received or at vehicle handover, to ensure that it appears free from any damage or defect, and matches the description provided.

If after accepting the Product, a defect appears in the manufacture or assembly of the Product before the end of the Warranty Period and Aussie Traveller finds the Product to be defective in materials or workmanship, Aussie Traveller will, in its sole discretion, either:

- a. replace, repair or refund the Product or the defective part of the Product free of charge; or
- b. cause the Product or the defective part of the Product to be replaced or repaired by a qualified repairer free of charge.

In arranging Warranty inspection, service and repair, Aussie Traveller will seek to provide the details of an approved service agent within your geographic area. Should one not be available, or if the Product is in use in travel, Aussie Traveller reserves the right to seek to arrange a repair or replacement at the next available location on the route of travel.

Aussie Traveller reserves the right to replace defective parts of the Product with parts and components of similar quality, grade and composition where an identical part or component is not available.

Products presented for repair may be replaced by refurbished goods of the same type rather than being repaired. Refurbished parts may be used to repair the Product.

## Aussie Traveller Awning Products

This Warranty covers specified defects in materials or workmanship for Awning Products as follows:

1. The vinyl fabric is warranted against:
  - a. holes caused by mildew (mildew will form on dust and dirt and stain fabric if fabric is not kept clean).
  - b. excessive cracking, peeling, hardening or loss of strength while used under normal conditions.
  - c. excessive fading (a slight colour change may occur due to ultraviolet rays).
2. All hardware components including the roller are warranted not to bend or break under normal use (excluding high winds, water pooling and accidents).

## Making a Warranty Claim

If a defect covered by this Warranty appears, the Customer must first contact Aussie Traveller within 7 days of first becoming aware of the defect. Aussie Traveller will assist the Customer to rectify and resolve any Product issue that may arise.

When making a claim under this Warranty, Aussie Traveller requires that the following information be provided before any further action will be taken.

1. Original Invoice (Document or Number);
2. Make and model of the Product;
3. Make and model of the vehicle (if Product fitted);
4. Vehicle build date (if Product fitted);
5. Vehicle chassis number;
6. Description of damage and/or repair required;
7. Photos of the damage and/or repair; and
8. Appropriate documentation (such as historical and maintenance records).

Aussie Traveller reserves the right to request more information or images should what is provided not be sufficient to make an assessment for the Warranty claim.

The Product must be made available to Aussie Traveller or its authorised repair agent for inspection and testing.

If such inspection and testing find no defect in the Product, the final retail customer must pay Aussie Traveller's usual costs of service work and testing.



The final retail customer must bear the cost of the transport of the Product to and from Aussie Traveller or the authorised repair agent, and all insurance of the Product.

## Exclusions

This Warranty will not apply where:

- the Product has been repaired, altered or modified by someone other than Aussie Traveller, or without the written consent of Aussie Traveller or an authorised repair agent;
- the alleged defect in the Product is within acceptable industry tolerances and variances;
- Aussie Traveller cannot establish any fault in the Product after testing and inspection;
- the Product has been used other than for the purpose for which it was designed;
- the alleged defect in the Product has arisen due to the final retail customer's failure to properly use and maintain the Product in accordance with any of Aussie Traveller's instructions, recommendations and specifications (including applicable maintenance schedules);
- the alleged defect in the Product has arisen due to the final retail customer's request to customise the Product;
- the Product has been subject to abnormal conditions, including environment temperature, high or excessive wind, water, fire, humidity, pressure, stress or similar;
- the alleged defect has arisen due to abuse, misuse, neglect or accident;
- unauthorised parts or accessories have been used on or in relation to the Product;
- the Product has been overloaded or involved in an accident;
- the alleged damage or defect has been caused by normal wear and tear
- the alleged damage to fabric has been caused by storm, wind or rain, or stretching of fabric caused by water pooling on fabric; breakage or bending of hardware components has been caused by storm, wind or rain, or water pooling on fabric.

## Replacement Warranty Item

If, under Warranty, a Product is replaced or repaired by Aussie Traveller or an Aussie Traveller agent, unless provided in writing to indicate otherwise, the replacement Product will carry the **remaining** Warranty terms and conditions, including length of time, of the original purchased Product.

## Change of Mind

Aussie Traveller understands that at times, final retail customers may change their mind. Choose carefully as return and credit requests for items purchased by mistake or "change of mind" reasons may not be approved. Aussie Traveller will not accept Product returns under these circumstances unless by written approval by an authorized Aussie Traveller representative. If approved, an administration and restocking fee may apply.

## Limitations

Aussie Traveller makes no express warranties or representations other than set out in this Warranty.

The repair or replacement of the Product or part of the Product is the absolute limit of Aussie Traveller's liability under this express Warranty.

To receive a copy of the Aussie Traveller Warranty Terms & Conditions or information regarding specific Aussie Traveller products, please contact Aussie Traveller Head Office on (07) 3284 3284 or email [enquiries@aussietraveller.com.au](mailto:enquiries@aussietraveller.com.au).

## CONTACT

### Australia Wide:

1300 663 868

### Melbourne

235 Barry Road  
Campbellfield, Melbourne, 3061  
Ph: +61 3 9357 6565  
[enquiries@aussietraveller.com.au](mailto:enquiries@aussietraveller.com.au)

### Brisbane

11-15 Oasis Court  
Clontarf, Brisbane, 4019  
Ph: +61 7 3284 3284  
[enquiries@aussietraveller.com.au](mailto:enquiries@aussietraveller.com.au)